

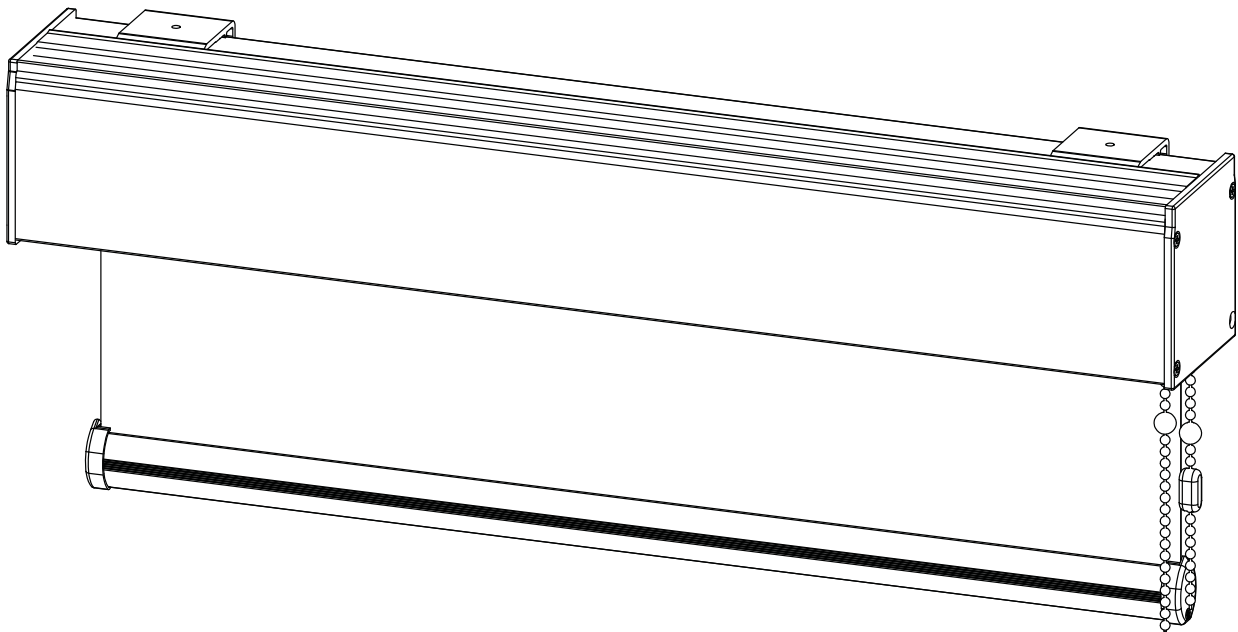

**ALTEX**<sup>®</sup>

SunProject™  
line of products

**DEKO<sup>®</sup> LITE-LIFT<sup>®</sup> CASSETTE S-70**  
**CHAIN OPERATED ROLLER SYSTEMS**



**DKO1-LL-S70**

**CASSETTE S70**



**ELEVATION**

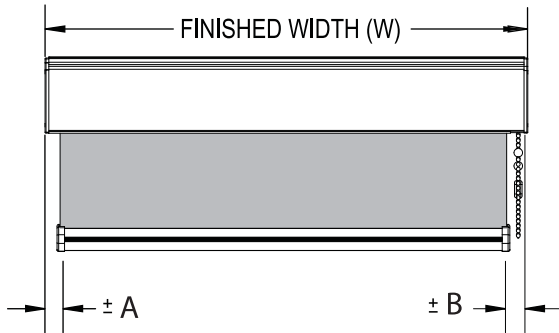

TOLERANCE +/- 1.5mm [0.0625"]  
DIMENSIONS mm [inches]

DIMENSION	FABRIC EDGE CLEARANCE [±mm / ±in] BY TUBE TYPE									
	32		38		46		53		63	
A	16	0.625	16	0.625	16	0.625	16	0.625	n/a	n/a
B	22	0.875	22	0.875	22	0.875	22	0.875	n/a	n/a

**MOUNTING**

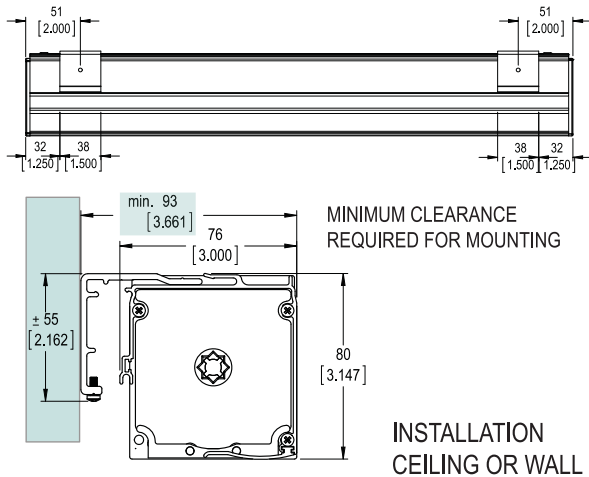

**SECTION**

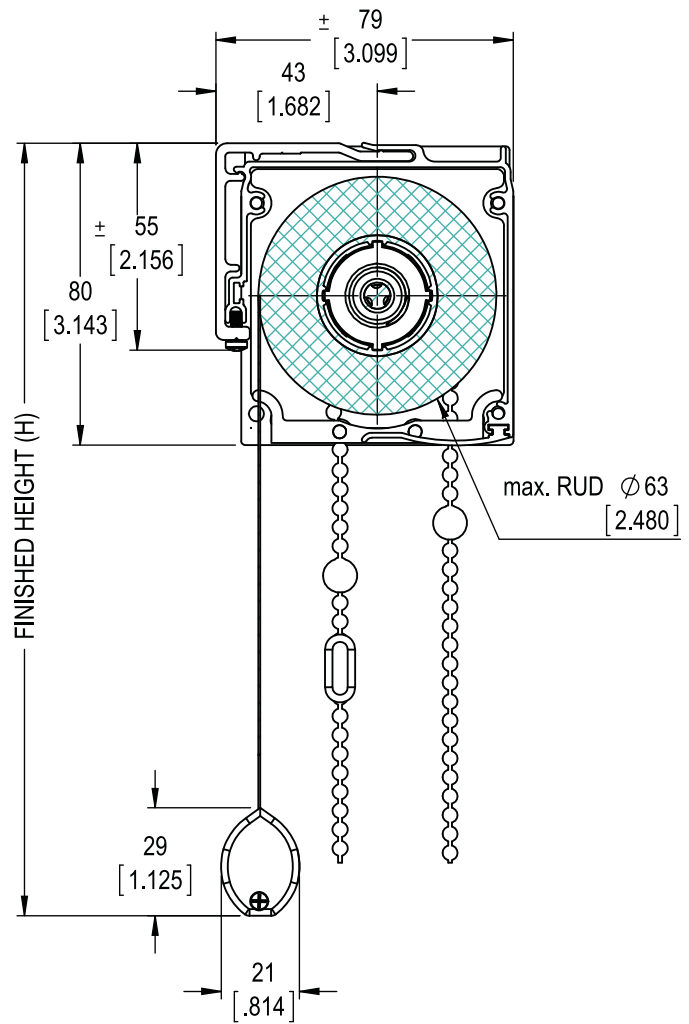

**MODEL**      **DKO-1-LL-S70**

**ROLL STYLE**

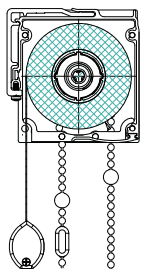

REGULAR ROLL

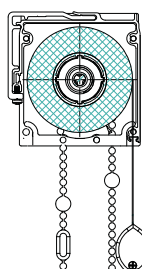

REVERSE ROLL

*NOTE: For size limitation guidelines, please refer to our Size Limitation Detail Sheets or contact our Technical Department.*

<b>MONTREAL</b> T: 800.363.5930 @: info@altex.ca	<b>TORONTO</b> T: 888.836.6980 @: sales@altex.ca	<b>VANCOUVER</b> T: 888.980.9899 @: servicewest@altex.ca
--	--	--